

Dimension

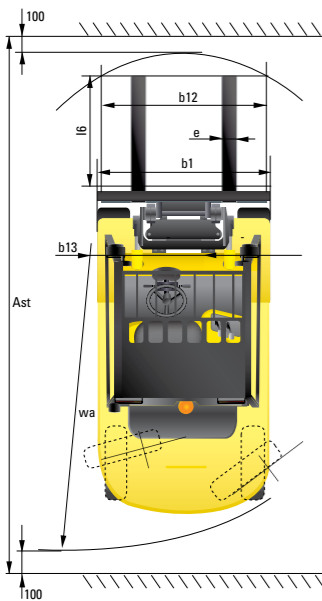

Specification

Identification					
1.1	Manufacturer	Hyundai	Hyundai	Hyundai	Hyundai
1.2	Manufacturer's type designation	20DF-7	25DF-7	30DF-7	33DF-7
1.3	Drive: electric (battery or mains), diesel, petrol, fuel gas, manual	DIESEL	DIESEL	DIESEL	DIESEL
1.4	Type of operation: hand, pedestrian, standing, seated, order-picker	seated	seated	seated	seated
1.5	Load capacity / rated load	kg 2,000	kg 2,500	kg 3,000	kg 3,300
1.6	Load center distance	c mm 500	c mm 500	c mm 500	c mm 500
1.8	Load distance, center of drive axle to fork	x mm 461	x mm 461	x mm 464	x mm 464
1.9	Wheelbase	y mm 1,650	y mm 1,650	y mm 1,700	y mm 1,700
Weights					
2.1	Service weight	kg 3,604	kg 3,894	kg 4,411	kg 4,823
2.2	Axle loading, loaded front/rear	kg 4,847 / 757	kg 5,579 / 815	kg 6,450 / 961	kg 6,885 / 1,238
2.3	Axle loading, unloaded front/rear	kg 1,683 / 1,921	kg 1,623 / 2,271	kg 1,748 / 2,663	kg 1,713 / 3,110
Wheels, Chassis					
3.1	Tires: solid rubber, superelastic, pneumatic, polyurethane	pneumatic	pneumatic	pneumatic	pneumatic
3.2	Tires size, front (Φ x width)	7.00-12-12PR	7.00-12-12PR	8.15-15-14PR	8.15-15-14PR
3.3	Tires size, rear (Φ x width)	6.00-9-10PR	6.00-9-10PR	6.50-10-12PR	6.50-10-12PR
3.5	Wheels, number front x rear (x=driven wheels)	x2 / 2	x2 / 2	x2 / 2	x2 / 2
3.6	Track width, front	mm 965	mm 965	mm 1,005	mm 1,005
3.7	Track width, rear	mm 980	mm 980	mm 980	mm 980
Basic Dimensions					
4.1	Mast / fork carriage tilt forward / backward (α/β)	degrees 6 / 10	degrees 6 / 10	degrees 6 / 10	degrees 6 / 10
4.2	Lowered mast height	h1 (mm) 2,175	h1 (mm) 2,175	h1 (mm) 2,190	h1 (mm) 2,190
4.3	Free lift	h2 (mm) 155	h2 (mm) 155	h2 (mm) 155	h2 (mm) 155
4.4	Lift height	h3 (mm) 3,300	h3 (mm) 3,300	h3 (mm) 3,200	h3 (mm) 3,200
4.5	Extended mast height	h4 (mm) 4,485	h4 (mm) 4,485	h4 (mm) 4,385	h4 (mm) 4,385
4.7	Overhead load guard (cab) height	h5 (mm) 2,160	h5 (mm) 2,160	h5 (mm) 2,180	h5 (mm) 2,180
4.8	Seat height / standing height	h7 (mm) 1,086	h7 (mm) 1,086	h7 (mm) 1,106	h7 (mm) 1,106
4.12	Coupling height	h10 (mm) 306	h10 (mm) 306	h10 (mm) 330	h10 (mm) 330
4.19	Overall length	l1 (mm) 3,577	l1 (mm) 3,632	l1 (mm) 3,738	l1 (mm) 3,806
4.20	Length to face of forks	l2 (mm) 2,527	l2 (mm) 2,582	l2 (mm) 2,688	l2 (mm) 2,756
4.21	Overall width	b1 (mm) 1,160	b1 (mm) 1,160	b1 (mm) 1,230	b1 (mm) 1,230
4.22	Fork dimensions (hook type)	s / e / l (mm) 1,050x100x45	s / e / l (mm) 1,050x100x45	s / e / l (mm) 1,050x125x45	s / e / l (mm) 1,050x125x45
4.23	Fork carriage ISO 2328, class / type A,B	2A	2A	3A	3A
4.24	Fork-carriage width	b12 (mm) 1,084	b12 (mm) 1,084	b12 (mm) 1,084	b12 (mm) 1,084
4.31	Ground clearance, loaded, under mast	m1 (mm) 114	m1 (mm) 108	m1 (mm) 115	m1 (mm) 115
4.32	Ground clearance, centre of wheelbase	m2 (mm) 185	m2 (mm) 185	m2 (mm) 198	m2 (mm) 198
4.33	Aisle width for pallets 1,000x1,200 crossways (LxW)	Ast1 (mm) 3,916	Ast1 (mm) 3,970	Ast1 (mm) 4,066	Ast1 (mm) 4,131
4.34	Aisle width for pallets 800x1,200 lengthways (WxL)	Ast2 (mm) 4,116	Ast2 (mm) 4,170	Ast2 (mm) 4,266	Ast2 (mm) 4,331
4.35	Turning radius	Wa (mm) 2,248	Wa (mm) 2,302	Wa (mm) 2,398	Wa (mm) 2,434
4.36	Smallest pivot point distance	b13 (mm) 714	b13 (mm) 714	b13 (mm) 731	b13 (mm) 731
Performance Data					
5.1	Travel speed, unloaded	km/h 17.6	km/h 17.6	km/h 18.5	km/h 19.7
5.2	Lift speed, loaded / unloaded	mm/s 570 / 590	mm/s 550 / 590	mm/s 460 / 480	mm/s 450 / 480
5.3	Lowering speed, loaded / unloaded	mm/s 500 / 450	mm/s 500 / 450	mm/s 500 / 450	mm/s 500 / 450
5.5	Drawbar pull, loaded	kg 2,257	kg 2,275	kg 2,161	kg 2,162
5.7	Gradient performance, loaded / unloaded	% 40.2 / 34.1	% 34.6 / 29.4	% 27.9 / 24.0	% 25.9 / 22.2
5.9	Acceleration time, loaded / unloaded (10m)	sec NA	sec NA	sec NA	sec NA
5.10	Service brake	FOOT	FOOT	FOOT	FOOT
Engine					
6.1	Engine manufacturer / type	HMC D4BB	HMC D4BB	HMC D4BB	KUBOTA V3600
6.2	Engine power acc. to ISO 1585	kW 39	kW 39	kW 39	kW 48
6.3	Rated speed	1/min 2,500	1/min 2,500	1/min 2,500	1/min 2,300
6.4	No. of cylinder / cubic capacity	anz/cm ³ 4 / 2,604	anz/cm ³ 4 / 2,604	anz/cm ³ 4 / 2,604	anz/cm ³ 4 / 3,620
6.5	Fuel consumption acc. To VDI cycle	ℓ/h 2.0	ℓ/h 2.2	ℓ/h 2.5	ℓ/h 2.6
Other Details					
8.1	Type of drive control	power shift	power shift	power shift	power shift
8.2	Operating pressure (system / attach)	bar/cm ² 200 / 165	bar/cm ² 200 / 165	bar/cm ² 200 / 165	bar/cm ² 200 / 165
8.3	Oil volume	ℓ 30	ℓ 30	ℓ 30	ℓ 30
8.4	Noise	db(A) 80	db(A) 80	db(A) 80	db(A) 80

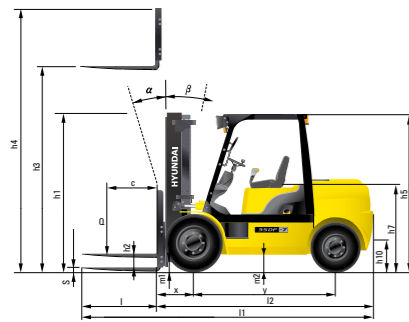

■ The photograph and the actual equipment may differ in appearance.

HYUNDAI DIESEL FORKLIFT TRUCKS Environmentally - Friendly

20/25/30/33/35DF-7

■ Contact your Hyundai dealer for more information. The machine shown may vary according to International standards.

HYUNDAI | FORKLIFT
HEAVY INDUSTRIES CO.,LTD.

Head Office (Sales Office)
14TH FL., HYUNDAI BLDG. 140-2, KYE-DONG, JONGNO-GU, SEOUL, KOREA 110-793
TEL (82) (2) 746-4609, 4638 FAX (82) (2) 746-7444-7445

Americas Operation : Hyundai Construction Equipment Americas, Inc.
955 ESTES AVENUE, ELK GROVE VILLAGE, IL. 60007, U.S.A. TEL (1) 847-437-3333 FAX (1) 847-437-3574

Europe Operation : Hyundai Heavy Industries Europe N.V.
VOSSENDAAL 11, 2440 GEEL, BELGIUM TEL (32) 14-56-2200 FAX (32) 14-59-3405

PLEASE CONTACT

www.hyundai-ce.com

2011. 03 Rev.0

HYUNDAI
HEAVY INDUSTRIES CO.,LTD.

We build a better future

20DF/25DF/30DF/33DF/35DF -7

New criterion of Forklift Trucks

Hyundai introduces a new line of 7series diesel forklift trucks.
Excellent power and performance makes your business more profitable.



■ The photograph and the actual equipment may differ in appearance.

High Power & Performance

Powerful Engine

HMC D4BB Engine (20/25/30/33DF-7) 39kW/2,500rpm



Market approved quality of HMC D4BB engine ensures incomparable performance, durability and additional value to the machine, 39kW of the engine is more than enough to suit any work, not just with normal 39kW but with special attachments requiring high power as well (Eu stage III A certified)

KUBOTA V3600 Engine (35DF-7) 48kW/2,300rpm



Market approved quality of Kubota V3600 engine ensures incomparable performance, durability and additional value to the machine. 48kW of the engine is more than enough to suit any work, not just with normal 48kW but with special attachments requiring high power as well. (EPA/EU Tier-3 Certified)

State-of-the-art hydraulic system

The latest large-capacity hydraulic system reacts quickly during operation, and a low-noise control valve increases both efficiency and durability.

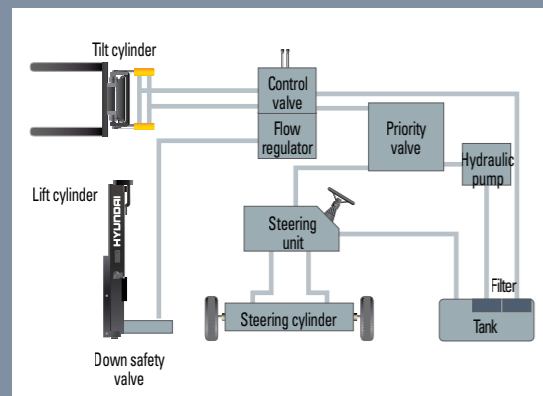

The new master on the job-site!

Smooth running, efficient and ergonomically designed, 20/25/30/33/35DF-7 series are made to meet your needs.

■ The photograph and the actual equipment may differ in appearance.



Fast and stable performance

Being able to quickly raise and lower the mast, as well as tilt it forward and backward, provides the best operational conditions during unloading. When the truck is fully loaded, mast lowering speed is carefully controlled to ensure safety by the down control valve.

Faster travel speed & gradeability

The powerful high-output engine provides greater acceleration, better gradeability and faster travel speed on any tough terrain or slope.



Increased mast tilting angle

Utilizing the standard mast tilting angle of 6 degrees forward and 10 degrees backward, the operator can safely and rapidly perform loading and unloading jobs.



Wet disc brake system

The wet disc brake system is virtually maintenance free and is enclosed to protect from dust and water.



Fully hydrostatic power steering

A hydraulic steering system always guarantees smooth and flexible steering, preventing overrun and kick-back.

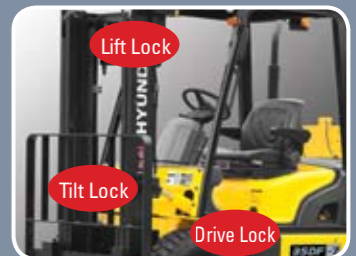

OPSS (Operator Presence Sensing System)

Control of mast tilting, lifting and lowering is not possible through operation of the appropriate control when the operator is not in the normal position.(Option)

Comfortable Operation



Adjustable steering wheel
Steering wheel with horn button can be adjusted by a lever on the right-hand side for the most comfortable operator position.



Easy and safe shift lever
A single lever on the left side of the steering column gives the operator fast, easy control of direction.



Multi-function switch lever
Multi-functional switch lever gives easy access to lights and horn.



Quick response of operating control levers
Only minimal operator's effort is required for precise, safe and productive control.



■ The photograph and the actual equipment may differ in appearance.

Ergonomically designed with the operator in mind!

A design based on human engineering relieves fatigue and increase operator's efficiency.



Ergonomically positioned pedals
Based on human engineering, the accelerator, brake and inching pedals are optimally positioned for convenience while operating the equipment.



Cup holder & console box
Additional storage spaces are located inside the operating space for operator's convenience.



New high visibility for safe operation
The operator is able to work with increased safety and accuracy due to a wider view mast.

Operator friendly gauges and water-resistant monitor panel



- 1 Parking brake lamp
- 2 Directional indicators
- 3 Fuel warning lamp
- 4 Engine oil warning lamp
- 5 Transmission oil temperature warning lamp
- 6 Battery charging warning lamp
- 7 Air cleaner filter warning light
- 8 Working light indicator
- 9 Water separator lamp
- 10 Pre-heater indicator
- 11 Water temperature gauge
- 12 Fuel gauge
- 13 Hour meter
- 14 Engine check lamp
- 15 Seat belt warning
- 16 OPSS warning(Optional)

Easily adjustable suspension seat

An attractive and adjustable seat, based on a human engineering design, provides great comfort, safety and durability.



Full floating overhead guard mount

The anti-vibration rubber is installed between the guard and truck frame to reduce the source of vibration and noise while driving. This not only reduces operator's fatigue but also increases safety.



Endurance & Safety

Strong overhead guard

The safety overhead guard exceeds EEC and ANSI regulations and protects the operator during hazardous jobs.



Parking brake

Ratchet type parking brake requires less efforts from the operator to set.



Highly durable split type drive axle

Powershift transmission provides fast travel speed and quiet travel under any heavy load condition, and boosts work efficiency.

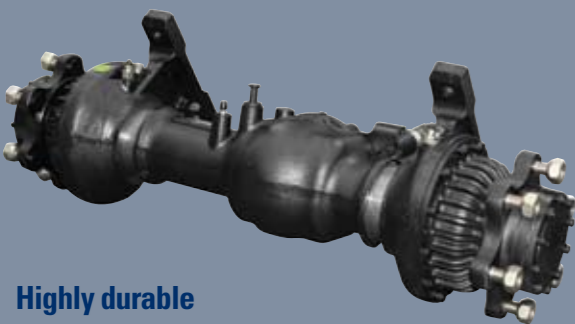

Enhanced safety through high durability!

Safety and durability are priorities in the design of the equipment.

■ The photograph and the actual equipment may differ in appearance.



Large footboard & hand grip

Wide "open" step offers convenience and safety when entering and exiting truck.

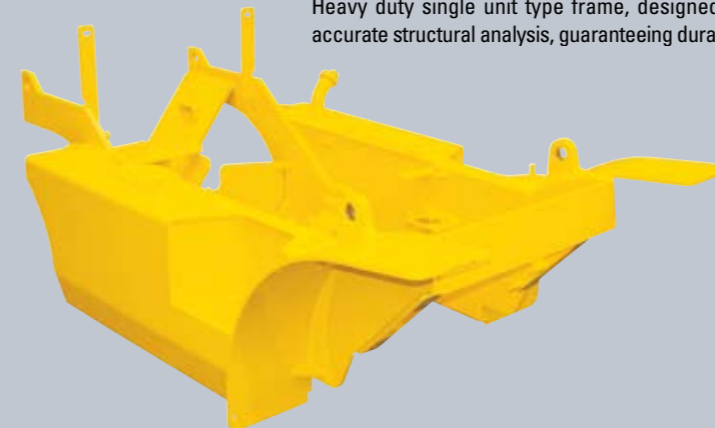

Heavy duty single unit frame

Heavy duty single unit type frame, designed on the basis of accurate structural analysis, guaranteeing durability and safety.



Easy access of electrical Components

Various electric parts are centralized in dash board resulting in improvement in maintenance



Bright, protected headlights

Bright, protected headlights is positioned for exceptional visibility.

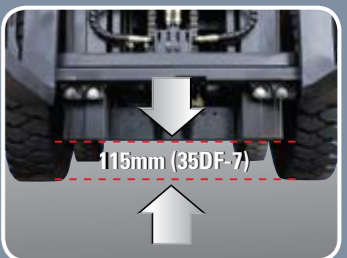

Ground clearance

The engine and transmission are assembled horizontally and positioned high in the frame to protect expansive components during operation on rugged surface.



Electrically monitored air filter

Air cleaner sensor alerts the operator of a restricted air filter and allows replacement before damage.



Brake fluid reservoir

Highly visible, easily accessible reservoir makes for quicker daily inspections.



An accessible, compact fuse box for easy inspection

Centralized design for easy service!

An ideal arrangement of component parts ensures easy access and convenience for maintenance.



■ The photograph and the actual equipment may differ in appearance.



Easy change air cleaner

The air filter is readily accessible for cleaning or replacement. (7inch Cyclone Type)



Tool-less floor plate for serviceability.



Large open engine hood

Highly accessible engine compartment assures fast and efficient maintenance.



Hydraulic oil check



Automatic self locking gas spring

Engine compartment hood is held safely open by a self locking gas spring.



Portable side cover

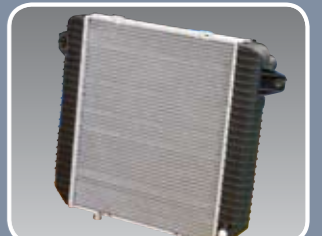

Aluminum radiator with superb protection against heat



Engine oil condition check

