



**ELECTRIC
TOWING TRACTORS**

NTT/NTF Series



The Power to Tow Heavy Loads with Ease

Based on the latest technology cultivated from more than 70 years of experience with electric forklift trucks, the NICHYU electric towing tractors feature clean, quiet and powerful operation in the field resulting in a better work environment.

With choices from a wide range of models, NICHYU tractors can be matched to the needs of a particular application such as plant, factory, market, railway station, airport, distribution center, and other facilities.

NICHYU developed the powerful drive motors, drive units and controls to provide high transporting efficiency. The power source is the industrial battery which provides a stable, safe and low cost operation when compared with the engine powered tractors. Each component and unit of the tractor are logically placed in the chassis for ease of maintenance. Charging the battery is also made easy by the automatic charger.

Clean, quiet battery power

Nichiyu, the battery forklift pioneer, introduces a clean, quiet, battery-powered towing tractor featuring a wide array of advanced mechatronics technology throughout. We offer several types with varied features, each of which is applicable to particular towing load and driving conditions.

The power to tow heavy loads

In addition to boasting increased power, these models incorporate Nichiyu's own motor, control system, drive system and other features. This powerful towing force greatly reduces the labor involved in the transportation tasks typical of a factory or market. What's more, the heavy towing capacity minimizes conveyance work between processes.

Low maintenance costs

Compared with gas-powered tractors, this battery-powered model uses a more stable, easy-to-use power supply (as provided by hydroelectric, thermal or nuclear power plants).

In addition, the low cost of recharging (fuel cost) is attractive, with each charge providing many hours of operation.

Operator-friendly operation system

Everything in this operator-centered design is focused on ergonomics, including a spacious seat, highly visible indicator panel and concentrated layout of the various controls.

NTT50-70

NTT75-70



NTT 100-70



NTT 90-70



NTT Series

Three Wheeler

Electric Towing Tractors

NTF Series

Four Wheeler



NTF200P

NTF360P

Electric Towing Tractors

NTT Series



NTT 50-70

Rated drawbar pull: 490N
Towing capacity: 2,000kg

NTT 75-70

Rated drawbar pull: 735N
Towing capacity: 3,000kg

A compact tractor with a small turning radius offering smooth, powerful travel and easy operation.

NTT 90-70

Rated drawbar pull: 882N
Towing capacity: 3,600kg

This compact truck handles large loads.

NTT 100-70

Rated drawbar pull: 980N
Towing capacity: 4,000kg

The Easy-to-Drive AC-controlled Towing Tractor with Turret-Style Steering

NTF 200P

Rated drawbar pull: 1,960N
Towing capacity: 8,000kg

NTF 360P

Rated drawbar pull: 3,530N
Towing capacity: 14,400kg

Ideal for towing large cargo for long hours

Operator Comfort

The round steering wheel gives this tractor a very car-like driving sensation.

The vehicle features an accelerator-off regenerative braking system that gently takes effect as you release the accelerator pedal. As a result, the braking effort is greatly reduced. In addition, the rearview mirrors and turn signals are provided as standard for enhanced safety.



Compact Design

The tractor has an overall length of only 1,345 mm.

What's more, the minimum turning radius of only 1,375mm makes this vehicle ideal for use in confined spaces.



Main Options

- Battery side-loading specification
- Overhead guard (with sheet)
- Coupler lever
- Rear combination lamp
- Bumper
- Suspension seat
- Hour meter

Traveling operation is locked out.

Operation Interlock System

For operator's safety, traveling is automatically locked when the operator is not properly seated.



Brake equipment

The brake is exerted by raising the handle by use of the electric brake function. Even when hands are off the handle, it returns to the brake position by spring force.

Smooth traveling AC control

Smooth inching (slow speed) running is possible by inverter control. This reduces operator fatigue and enhances work efficiency.

Easy operation with electric power steering

Featuring the electric power steering, the truck can be operated with little effort thanks to the steering handle's convenient position and short arm. Centralized arrangement of acceleration grip and safety button at the handle top portion. This allows for easy operation in safety. Moreover, the non-slip handle grip can be grasped firmly for sure operation.



For More Comfortable and Safe Operation

Equipped with AC Control System & All-Gear Drive

This Towing Tractor features AC control for smoother, more powerful acceleration. What's more, it's equipped with a regenerative braking system that applies an electrical braking force when the accelerator ring is released. In addition, the innovative "All-Gear Drive System" replaces our conventional chain drive, eliminating chain noise. The result is an amazingly comfortable ride.

Low Floor for Easier Getting On and Off Emergency Stop Button on Top Cover

The floor height is only 290 mm, a full 110 mm lower than our conventional towing tractor.

Easy access to the Emergency Stop button on the top cover helps to prevent sudden accidents.

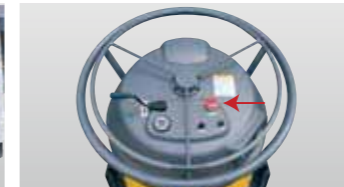
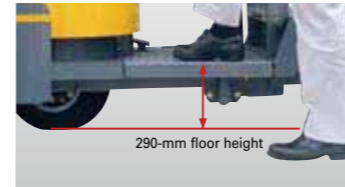

Smooth Deceleration on Downslopes

The regenerative braking ensures smooth deceleration when the accelerator is released on a downslope. It's also powerful enough to climb upslopes.

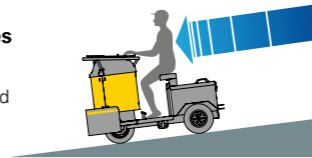

Easier Maintenance

All-Gear Drive with No Chain Adjustments

Maintenance is easier than ever now that troublesome chain adjustments have been eliminated.



LCD Battery Capacity Meter (with hour meter)

Remaining battery capacity is clearly displayed on the 10-step scale. The display also features an hour meter.



Controller

Adopts the FET chopper method superior in efficiency and reliability to the traveling control. Realizes smooth and robust acceleration without sudden change in speed, which contributes to energy saving.

Brake equipment

Exerts a smooth electric brake by changing the forward/backward lever during traveling, in addition to braking by foot brake.

Drive unit

Adopts rear-wheel drive with a four-wheel type exerting stable traveling and sufficient traction.

Operating device

Designed for the benefit of operators based on human engineering including a comfortable (easygoing) driver's seat, easy-to-see indicator panel, and centralized arrangement of various operating devices.



Easy-disconnect trailer coupler (NTF200P)

Electric Towing Tractors

Model		NTT Series				NTF Series			
		NTT 50-70	NTT 75-70	NTT 90-70	NTT 100-70	NTF 200P	NTF 360P		
Performance	Rated drawbar pull	N/[kgf]	490 [50]	735 [75]	882 [90]	980 [100]	1,960 [200]	3,530 [360]	
	Towing capacity	(kg)	2,000	3,000	3,600	4,000	8,000	14,400	
	Travel speed	Laden	(kg)	7.0	6.0	5.0	6.0	7.0	6.0
		Unladen	(kg)	8.0	8.0	7.0	14.0	15.0	12.0
	Gradeability (laden)	(km/h)	—	—	—	4	—	—	
Min.turning radius	(km/h)	1,375	1,375	1,170	1,530	2,050	2,150		
Dimensions	Overall length (incl.coupler)	(%)	1,345	1,345	1,390	1,895	2,220	2,520	
	Length of coupler	(mm)	95	95	60	85	120	170	
	Overall width	(mm)	825	825	825	1,100	1,090	1,175	
	Overall height	(mm)	1,180	1,180	1,400	1,240	1,570	1,660	
	height of coupler center (from floor)	(mm)	280	280	150 ~ 420	320	450	350	
	Wheelbase	(mm)	900	900	945	1,100	1,250	1,400	
		Overhang	Front	(mm)	210	210	210	430	400
	Rear		(mm)	140	140	140	280	450	500
	Tread	Front	(mm)	—	—	—	—	900	980
		Rear	(mm)	685	685	717	980	900	955
Service weight (without battery)	(mm)	385	415	645	595	1,195	1,735		
Battery weight	Min. / Max.	190 / 210	210 / 230	130 / 180	160 / 310	590 / 610	975 / 1,005		
Tyre	Tyre		Rubber	Rubber	(F) Rubber (R) Urethane	(F) Solid (R) Solid	Pneumatic		
	Front tyre (quantity)		ø235 x 120 (1)	ø235 x 120 (1)	ø215 x 84 (1)	4.00-8 (1)	5.00-8-8PR (2)	6.00-9-10PR (2)	
	Rear tyre (quantity)		ø178 x 73 (2)	ø178 x 73 (2)	ø152 x 76 (2)	4.00-8 (2)	21x8-9-14PR (2)	23x9-10-16PR (2)	
Motor	(kW)	1.6	1.6	1.6	2.6	7.8	10.0		
Control system		Inverter		Inverter control	Inverter control	Chopper control			
Battery	Standard	24V 216Ah / 5HR	24V 250Ah / 5HR	24V 201Ah / 5HR	48V 100Ah / 5HR	48V 330Ah / 5HR	72V 400Ah / 5HR		
	Option	250Ah / 5HR	—	250Ah / 5HR	130, 140, 200Ah / 5HR	—	—		
Charger		Automatic stationary charger	Automatic stationary charger	Automatic stationary charger	Automatic stationary charger	Automatic stationary charger			

Notes : Towing capacity was calculated under flat road and rolling resistance 0.025.
*All specifications are subject to change without notice due to further improvement or modifications.

Standard and Optional Equipment

Model	NTT 50-75	NTT 90	NTT 100	NTT 200P-360P
Headlight (s)	●	▲	●	●
Turn-signal lamps	●	—	—	●
Rear combination lamps	▲	—	—	●
Horn	●	●	●	●
Back buzzer	▲	▲	▲	●
Rear view mirrors	●	—	—	●

● : Standard ▲ : Option — : Not Available

NTT50 / 75

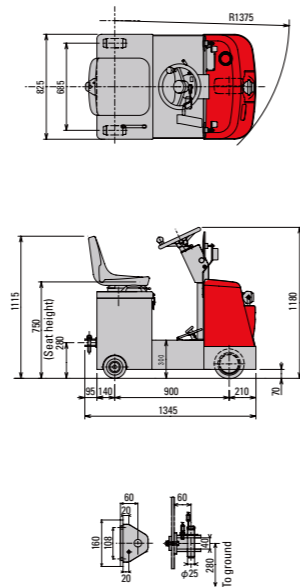

NTT90

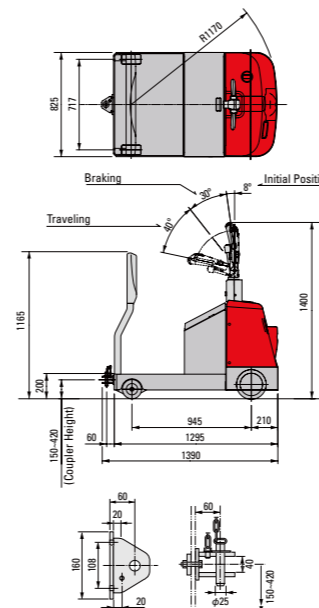

NTT100

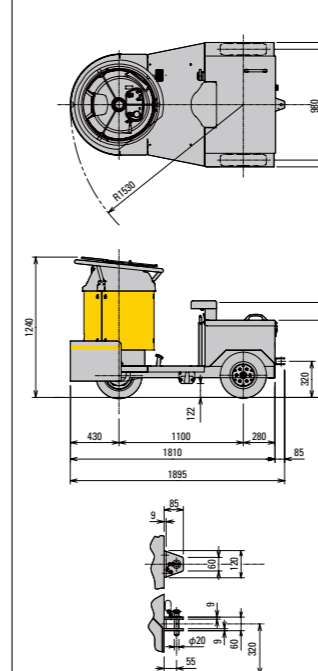

NTF200P

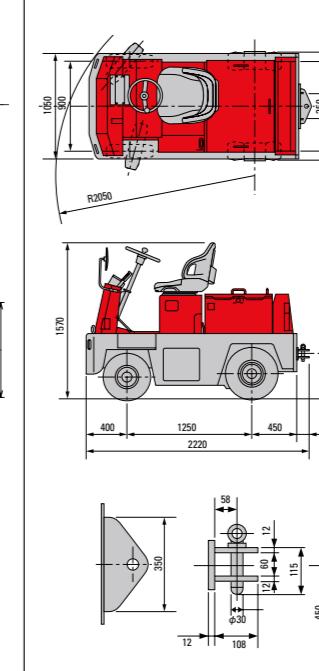

NTF360P

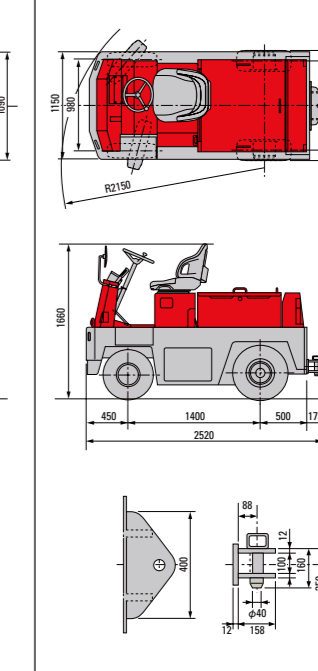

All specifications have been determined according to Nichiyu's terms and conditions.
Specifications are subject to change without notice in the interests of product improvement.

NICHIYU

Nippon Yusoki Co., Ltd.

1-1, 2-Chome, Higashikotari, Nagaokakyo-shi, Kyoto 617-8585 JAPAN
Tel: +81-(0)75-956-8622 Fax: +81-(0)75-955-0480 URL: <http://www.nichiyunet.co.jp/en>

CAT No.OSD092/K-1 Printed in Japan 5000/0908(SK)