



## 7 Series Forklifts

### Pneumatic Diesel 2.0 to 3.5 ton Series

D20S/D25S/D30S/D33S-7, D35C-7 with Yanmar 3.3L  
EPA Interim tier-4, Euro Stage IIIA



*Building your tomorrow today*

# Technical Data according to VDI 2198

Characteristics			Doosan	Doosan	Doosan	Doosan	Doosan		
			D20S-7	D25S-7	D30S-7	D33S-7	D35C-7		
1.1	Manufacturer		Doosan	Doosan	Doosan	Doosan	Doosan		
1.2	Model designation		D20S-7	D25S-7	D30S-7	D33S-7	D35C-7		
1.3	Drive: Diesel, Gasoline, LP		Diesel	Diesel	Diesel	Diesel	Diesel		
1.4	Operator type: Hand, Pedestrian, Standing, Seated, Order-picker		Seated	Seated	Seated	Seated	Seated		
1.5	Load Capacity	Q	kg	2,000	2,500	3,000	3,250	3,500	
1.6	Load Center	c	mm	500	500	500	500	500	
1.8	Load Distance: Center of Driveaxle to fork	x	mm	485	485	485	485	495	
1.9	Wheelbase	y	mm	1,625	1,625	1,700	1,700	1,700	
Weight	2.1	Service weight		kg	3,690	4,065	4,450	4,630	4,810
	2.2	Axle Loading, Laden Front/Rear		kg	4,930/650	5,660/790	6,580/870	6,940/940	7,340/970
	2.3	Axle Loading, Unladen Front/Rear		kg	1,720/1,860	1,650/2,300	1,840/2,610	1,800/2,830	1,780/3,030
Tyres	3.1	Tyres: pneumatic (P), superelastic (SE), cushion (C)			P	P	P	P	P
	3.2	Tyre size, Front			7.00x15-12	7.00x15-12	28x9x15-12	28x9x15-12	250x15-18
	3.3	Tyre size, Rear			6.50x10-10	6.50x10-10	6.50x10-10	6.50x10-12	6.50x10-12
	3.5	Wheels, number Front/Rear (x = driven wheels)			2x/2	2x/2	2x/2	2x/2	2x/2
	3.6	Tread, Front	b11	mm	975	975	982	982	1,026
	3.7	Tread, Rear	b12	mm	1,000	1,000	1,000	1,000	1,000
	4.1	Tilt of Mast/Fork carriage Forward/Backward		α/β	°	6/10	6/10	6/10	6/10
4.2	Height, Mast lowered		h1	mm	2,175	2,175	2,165	2,165	2,165
4.3	Free Lift		h2	mm	152	152	152	152	152
4.4	Lift		h3	mm	3,230	3,230	3,230	3,230	3,230
4.5	Height, Mast Extended		h4	mm	4,490	4,490	4,490	4,490	4,260
4.7	Height of Overhead Guard(Cabin)		h6	mm	2,183	2,183	2,183	2,183	2,183
4.8	Height of Seat		h7	mm	1,026	1,026	1,026	1,026	1,026
4.19	Overall Length		l1	mm	3,565	3,630	3,744	3,774	3,809
4.20	Length to Forkface		l2	mm	2,530	2,595	2,700	2,730	2,765
4.21	Overall Width		b1/b2	mm	1,170	1,170	1,197	1,197	1,255
4.22	Fork Dimensions		s/e/l	mm	40x100x1,050	40x100x1,050	45x125x1,050	45x125x1,050	45x125x1,050
4.23	Fork carriage ISO 2328, class/type A,B				II/A	II/A	III/A	III/A	III/A
4.24	Fork carriage width		b3	mm	1,103	1,103	1,115	1,115	1,115
4.31	Ground Clearance, laden, below mast		m1	mm	115	115	105	105	105
4.32	Ground Clearance, center of wheelbase		m2	mm	143	143	143	143	143
4.34.1	Aisle width for pallets 1,000 x 1,200 crossways		Ast	mm	3,800	3,845	3,950	3,980	4,015
4.34.2	Aisle width for pallets 800 x 1,200 crossways		Ast	mm	3,600	3,645	3,750	3,780	3,815
4.35	Turning Radius		Wa	mm	2,220	2,265	2,365	2,395	2,420
4.36	Internal Turning Radius		b13	mm	775	775	761	761	761
Performance data	5.1	Travel Speed, Laden/Unladen		km/h	19/19.5	19/19.5	18/18.5	18/18.5	18.5/19
	5.2	Lift Speed, Laden/Unladen		m/s	0.53/0.55	0.52/0.55	0.50/0.55	0.49/0.55	0.42/0.55
	5.3	Lowering Speed, Laden/Unladen		m/s	0.51/0.46	0.51/0.46	0.51/0.46	0.51/0.46	0.51/0.46
	5.5	Drawbar pull, Laden/Unladen(@ 1.6km/h)		N	17,350/17,130	17,160/17,060	17,960/17,620	17,870/17,720	17,220/17,160
	5.6	Max. Drawbar pull, Laden/Unladen		N	20,100/19,780	19,920/19,720	21,080/20,510	20,990/20,650	20,150/19,950
	5.7	Gradeability, Laden/Unladen(@ 1.6km/h)		%	33.0/55.0	28.2/50.0	25.0/43.5	23.5/42.5	21.5/40.0
5.8	Max. Gradeability, Laden/Unladen		%	38.5/66.5	33.0/60.3	29.5/52.0	27.5/50.5	25.0/47.0	
5.10	Service Brake			foot/hydraulic	foot/hydraulic	foot/hydraulic	foot/hydraulic	foot/hydraulic	
Combustion Engine	7.1	Engine Manufacturer/type			YANMAR/4TNE98	YANMAR/4TNE98	YANMAR/4TNE98	YANMAR/4TNE98	YANMAR/4TNE98
	7.2	Engine power according to DIN ISO1585		kW	43.7	43.7	43.7	43.7	43.7
	7.3	Rated Speed		min-1	2,300	2,300	2,300	2,300	2,300
	7.3.1	Torque at 1/min		N•m	191/1,600	191/1,600	191/1,600	191/1,600	191/1,600
	7.4	Number of Cylinders/Displacement		-/cm3	4/4/3,319	4/4/3,319	4/4/3,319	4/4/3,319	4/4/3,319
7.10	Battery Voltage/normal capacity		V/Ah	12/85	12/85	12/85	12/85	12/85	
Addition Data	10.1	Operating pressure for attachments		bar	156	156	156	156	156
	10.2	Oil volume for attachments		l/min	60	60	60	60	60
	10.4	Fuel Tank Capacity		l	51	51	51	51	51
	10.7	Sound level at th driver's ear according to EN 12 053		dB(A)	84	84	84	84	84

# MAST SPECIFICATION and RATED CAPACITIES

## D20S-7

Mast type	Maximum Fork Height	Maximum Lowered Height	Fully Extended Height	Free Lift	Rated Load Capacities											
					D20S-7											
					Tilt Angle						Load Capacities					
					Single Pneu.		Double Pneu		Single Solid		Single Pneu.		Double Pneu		Single Solid	
FWD	BWD	FWD	BWD	FWD	BWD	LC 500mm	LC 24in	LC 500mm	LC 24in	LC 500mm	LC 24in					
deg		deg		deg		kg	lb	kg	lb	kg	lb					
STD	2,030	1,575	3,290	147	6	10	6	10	6	10	2,000	4,000	2,000	4,000	2,000	4,000
	2,580	1,850	3,840	147	6	10	6	10	6	10	2,000	4,000	2,000	4,000	2,000	4,000
	2,950	2,035	4,210	147	6	10	6	10	6	10	2,000	4,000	2,000	4,000	2,000	4,000
	3,230	2,175	4,490	147	6	10	6	10	6	10	2,000	4,000	2,000	4,000	2,000	4,000
	3,500	2,425	4,765	147	6	10	6	10	6	10	2,000	4,000	2,000	4,000	2,000	4,000
	3,800	2,575	5,065	147	6	10	6	10	6	10	2,000	4,000	2,000	4,000	2,000	4,000
	3,950	2,650	5,215	147	6	10	6	10	6	10	2,000	4,000	2,000	4,000	2,000	4,000
	4,350	2,850	5,615	147	6	10	6	10	6	10	2,000	4,000	2,000	4,000	2,000	4,000
4,960	3,150	6,215	147	6	5	6	10	6	10	1,900	3,750	1,925	3,900	1,975	4,000	
FF	2,580	1,850	3,840	645	6	10	6	10	6	10	2,000	4,000	2,000	4,000	2,000	4,000
	2,950	2,035	4,210	830	6	10	6	10	6	10	2,000	4,000	2,000	4,000	2,000	4,000
	3,230	2,175	4,490	970	6	10	6	10	6	10	2,000	4,000	2,000	4,000	2,000	4,000
	3,600	2,425	4,865	1,220	6	10	6	10	6	10	2,000	4,000	2,000	4,000	2,000	4,000
FFT	3,900	1,875	5,165	670	6	8	6	8	6	8	2,000	4,000	2,000	4,000	2,000	4,000
	4,290	2,015	5,570	805	6	8	6	8	6	8	2,000	4,000	2,000	4,000	2,000	4,000
	4,730	2,150	5,990	945	6	8	6	8	6	8	1,950	3,950	1,950	3,950	2,000	4,000
	4,805	2,175	6,065	970	6	5	6	8	6	8	1,950	3,950	1,925	3,950	2,000	4,000
	5,560	2,500	6,815	1,295	6	3	6	8	6	8	1,650	3,650	1,825	3,700	1,875	3,850
	6,010	2,650	7,265	1,445	6	3	6	8	6	5	1,300	2,900	1,750	3,550	1,825	3,700

## D25S-7

Mast type	Maximum Fork Height	Maximum Lowered Height	Fully Extended Height	Free Lift	Rated Load Capacities											
					D25S-7											
					Tilt Angle						Load Capacities					
					Single Pneu.		Double Pneu		Single Solid		Single Pneu.		Double Pneu		Single Solid	
FWD	BWD	FWD	BWD	FWD	BWD	LC 500mm	LC 24in	LC 500mm	LC 24in	LC 500mm	LC 24in					
deg		deg		deg		kg	lb	kg	lb	kg	lb					
STD	2,030	1,575	3,290	147	6	10	6	10	6	10	2,500	5,000	2,500	5,000	2,500	5,000
	2,580	1,850	3,840	147	6	10	6	10	6	10	2,500	5,000	2,500	5,000	2,500	5,000
	2,950	2,035	4,210	147	6	10	6	10	6	10	2,500	5,000	2,500	5,000	2,500	5,000
	3,230	2,175	4,490	147	6	10	6	10	6	10	2,500	5,000	2,500	5,000	2,500	5,000
	3,500	2,425	4,765	147	6	10	6	10	6	10	2,500	5,000	2,500	5,000	2,500	5,000
	3,800	2,575	5,065	147	6	10	6	10	6	10	2,500	5,000	2,500	5,000	2,500	5,000
	3,950	2,650	5,215	147	6	10	6	10	6	10	2,500	5,000	2,500	5,000	2,500	5,000
	4,350	2,850	5,615	147	6	5	6	10	6	10	2,500	5,000	2,500	5,000	2,500	5,000
4,960	3,150	6,215	147	6	3	6	10	6	10	2,075	4,600	2,450	4,950	2,500	5,000	
FF	2,580	1,850	3,840	645	6	10	6	10	6	10	2,500	5,000	2,500	5,000	2,500	5,000
	2,950	2,035	4,210	830	6	10	6	10	6	10	2,500	5,000	2,500	5,000	2,500	5,000
	3,230	2,175	4,490	970	6	10	6	10	6	10	2,500	5,000	2,500	5,000	2,500	5,000
	3,600	2,425	4,865	1,220	6	10	6	10	6	10	2,500	5,000	2,500	5,000	2,500	5,000
FFT	3,900	1,875	5,165	670	6	8	6	8	6	8	2,500	5,000	2,500	5,000	2,500	5,000
	4,290	2,015	5,570	805	6	5	6	8	6	8	2,500	5,000	2,500	5,000	2,500	5,000
	4,730	2,150	5,990	945	6	3	6	8	6	8	2,450	5,000	2,500	5,000	2,500	5,000
	4,805	2,175	6,065	970												

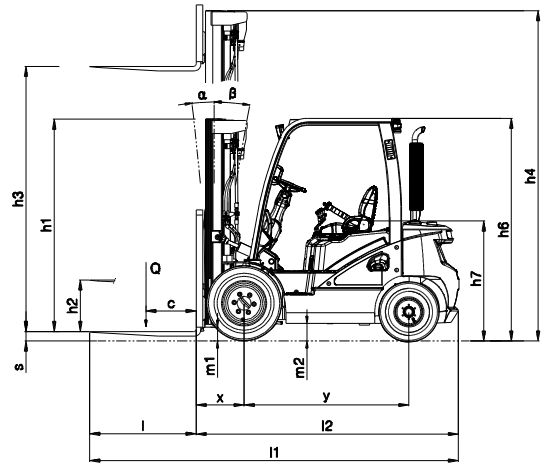
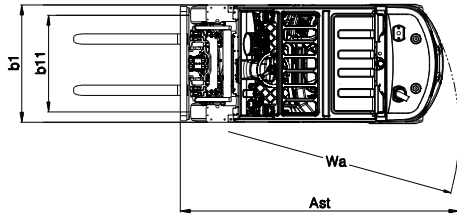

### D33S-7

Mast type	Maximum Fork Height	Maximum Lowered Height	Fully Extended Height	Free Lift	Rated Load Capacities													
					D33S-7													
					With Load Backrest	With Load Backrest	Tilt Angle						Load Capacities					
							Single Pneu.		Double Pneu		Single Solid		Single Pneu.		Double Pneu		Single Solid	
FWD	BWD	FWD	BWD	FWD	BWD	FWD	BWD	LC 500mm	LC 24in	LC 500mm	LC 24in	LC 500mm	LC 24in					
	mm	mm	mm	mm	deg	deg	deg	deg	deg	deg	kg	lb	kg	lb	kg	lb		
STD	2,030	1,565	3,290	152	6	10	6	10	6	10	3,250	6,500	3,250	6,500	3,250	6,500		
	2,580	1,840	3,840	152	6	10	6	10	6	10	3,250	6,500	3,250	6,500	3,250	6,500		
	2,950	2,025	4,210	152	6	10	6	10	6	10	3,250	6,500	3,250	6,500	3,250	6,500		
	3,230	2,165	4,490	152	6	10	6	10	6	10	3,250	6,500	3,250	6,500	3,250	6,500		
	3,500	2,415	4,765	152	6	10	6	10	6	10	3,250	6,500	3,250	6,500	3,250	6,500		
	3,800	2,565	5,065	152	6	10	6	10	6	10	3,250	6,500	3,250	6,500	3,250	6,500		
	3,950	2,640	5,215	152	6	10	6	10	6	10	3,175	6,500	3,250	6,500	3,250	6,500		
	4,350	2,840	5,615	152	6	5	6	10	6	10	3,175	6,500	3,250	6,500	3,250	6,500		
4,960	3,140	6,215	152	6	3	6	10	6	8	2,450	5,400	3,125	6,350	3,200	6,500			
FF	2,580	1,840	3,840	640	6	10	6	10	6	10	3,250	6,500	3,250	6,500	3,250	6,500		
	2,950	2,025	4,210	825	6	10	6	10	6	10	3,250	6,500	3,250	6,500	3,250	6,500		
	3,230	2,165	4,490	965	6	10	6	10	6	10	3,250	6,500	3,250	6,500	3,250	6,500		
	3,600	2,415	4,865	1,215	6	10	6	10	6	10	3,250	6,500	3,250	6,500	3,250	6,500		
FFT	3,900	1,890	5,165	690	6	8	6	8	6	8	3,250	6,500	3,250	6,500	3,250	6,500		
	4,290	2,025	5,570	825	6	8	6	8	6	8	3,250	6,500	3,250	6,500	3,250	6,500		
	4,730	2,165	5,990	965	6	3	6	8	6	8	2,900	6,300	3,175	6,450	3,250	6,500		
	5,560	2,515	6,815	1,315	6	3	6	8	6	5	1,750	3,950	2,975	6,050	3,050	6,200		
	6,010	2,665	7,265	1,465	6	3	6	5	6	3	1,350	3,050	2,875	5,850	2,950	6,050		

### D35C-7

Mast type	Maximum Fork Height	Maximum Lowered Height	Fully Extended Height	Free Lift	Rated Load Capacities													
					D35C-7													
					With Load Backrest	With Load Backrest	Tilt Angle						Load Capacities					
							Single Pneu.		Double Pneu		Single Solid		Single Pneu.		Double Pneu		Single Solid	
FWD	BWD	FWD	BWD	FWD	BWD	FWD	BWD	LC 500mm	LC 24in	LC 500mm	LC 24in	LC 500mm	LC 24in					
	mm	mm	mm	mm	deg	deg	deg	deg	deg	deg	kg	lb	kg	lb	kg	lb		
STD	1,800	1,565	3,290	152	6	10	6	10	6	10	3,500	7,000	3,500	7,000	3,500	7,000		
	2,350	1,840	3,610	152	6	10	6	10	6	10	3,500	7,000	3,500	7,000	3,500	7,000		
	2,720	2,025	3,980	152	6	10	6	10	6	10	3,500	7,000	3,500	7,000	3,500	7,000		
	3,000	2,165	4,260	152	6	10	6	10	6	10	3,500	7,000	3,500	7,000	3,500	7,000		
	3,495	2,415	4,760	152	6	10	6	10	6	10	3,500	7,000	3,500	7,000	3,500	7,000		
	3,655	2,565	4,915	152	6	10	6	10	6	10	3,500	7,000	3,500	7,000	3,500	7,000		
	3,805	2,640	5,065	152	6	10	6	10	6	10	3,500	7,000	3,500	7,000	3,500	7,000		
	4,205	2,840	5,465	152	6	8	6	10	6	10	3,425	6,950	3,425	6,950	3,500	7,000		
	4,805	3,140	6,065	152	6	3	6	8	6	8	3,250	6,650	3,275	6,650	3,375	6,850		
FF	2,350	1,840	3,610	640	6	10	6	10	6	10	3,500	7,000	3,500	7,000	3,500	7,000		
	2,720	2,025	3,980	825	6	10	6	10	6	10	3,500	7,000	3,500	7,000	3,500	7,000		
	3,000	2,165	4,260	965	6	10	6	10	6	10	3,500	7,000	3,500	7,000	3,500	7,000		
	3,495	2,415	4,755	1,215	6	10	6	10	6	10	3,500	7,000	3,500	7,000	3,500	7,000		
FFT	3,555	1,890	4,815	690	6	8	6	8	6	8	3,400	7,000	3,400	7,000	3,400	7,000		
	3,960	2,025	5,220	825	6	8	6	8	6	8	3,400	7,000	3,400	7,000	3,400	7,000		
	4,380	2,165	5,640	965	6	5	6	8	6	8	3,375	6,850	3,375	6,850	3,400	7,000		
	4,820	2,335	6,085	1,135	6	3	6	8	6	8	3,250	6,600	3,250	6,650	3,350	6,800		
	5,205	2,515	6,465	1,315	6	3	6	8	6	5	2,600	5,800	3,150	6,450	3,250	6,600		
	5,655	2,665	6,915	1,465	6	3	6	8	6	3	1,975	4,450	3,050	6,200	3,150	6,400		



AUTHORIZED DEALER