

ELECTRIC LIFT TRUCK SPECIFICATIONS

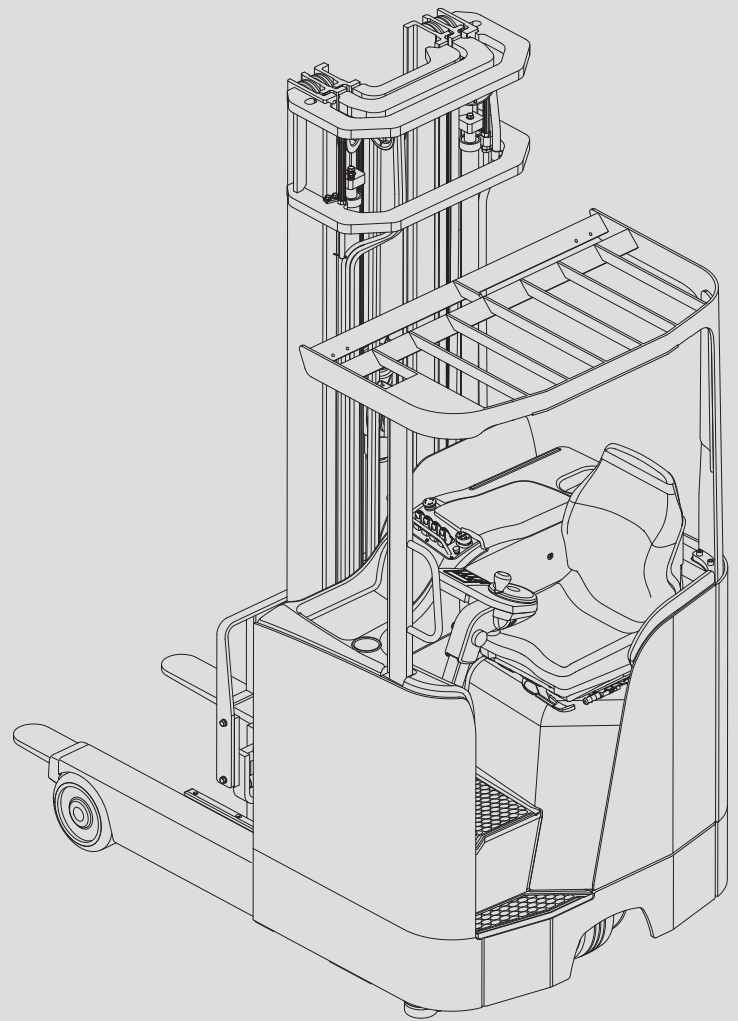

SIT-ON REACH TRUCK

75 SERIES

FBRF14/16/20

Standard Specifications

		Item	Summary	Unit	NICHYU			
Type	1.2	Model			FBRF14	FBRF16	FBRF20	
	1.3	Rated capacity	with Integral sideshifter	Q kg	1400	1600	2000	
	1.4	Load center		C mm	600	600	600	
	1.5	Motor type			AC	AC	AC	
	1.6	Operator type	Stand-on / Seated		Seated	Seated	Seated	
	Dimensions	2.1	Lift height		H ₃ +s mm	6000	6000	6000
2.2		Free lift		H ₂ +s mm	1765	1765	1775	
2.3		Tilt angle <Fork>	Downward / Upward		deg. 2 / 5	2 / 5	2 / 5	
2.4		Fork	Finger bar		Hook type	Hook type	Hook type	
2.5			Dimensions (L / W / T)	l/b/s mm	1070 / 100 / 35	1070 / 122 / 40	1070 / 122 / 40	
2.6			Spread (Max / Min)	B ₅ mm	715 / 200	737 / 292	737 / 292	
2.7			OA. length	L ₁ mm	2280	2280	2360	
2.8		Length	Frame	L ₇ mm	1730	1830	1890	
2.9			to Fork face	L ₂ mm	1210	1210	1290	
2.10		Reach stroke		L ₄ mm	555	655	625	
2.11		Width	OA. width	B mm	1270	1270	1334	
2.12			Between legs	B ₄ mm	932	932	915	
2.13			Frame	B ₂ mm	1270	1270	1270	
2.14		Height	Leg	H ₈ mm	275	275	291	
2.15			Mast lowered	H ₁ mm	2665	2665	2675	
2.16			Mast extended	H ₄ mm	6900	6900	6900	
2.17			Overhead guard	H ₆ mm	2160	2160	2190	
2.18		Overhang	Reach out	X mm	180	180	180	
2.19		Min. turning radius		Wa mm	1610	1705	1755	
2.20		Min. 90° turning aisle ^{*1)}	W800 x L1200 Pallet		mm 1825	1870	1920	
			W1200 x L1200 Pallet		mm 1825	1870	1920	
2.21	Min. 90° stacking aisle ^{*1)}	W800 x L1200 Pallet	Ast mm	2520	2535	2610		
		W1200 x L1200 Pallet	Ast mm	2630	2645	2720		
Performance	3.1	Travel speed	Laden / Unladen	km/h	12 / 12	12 / 12	12 / 12	
	3.3	Lifting speed	Laden / Unladen	mm/s	370 / 560	370 / 560	300 / 460	
	3.4	Lowering speed	Laden / Unladen	mm/s	500 / 400	500 / 400	500 / 400	
	3.5	Reach speed	Laden / Unladen	mm/s	150 / 200	150 / 200	150 / 200	
	3.6	Gradeability		%	10 / 15	10 / 15	10 / 15	
	Mass	4.1	Service weight	w/o Battery	kg	2365	2415	2730
4.2		Axle loading Incl. Battery (6.3)	Reach-in	Laden (Load / Drive)	kg	2785 / 1730	2910 / 1855	3590 / 2080
4.3				Unladen (Load / Drive)	kg	1150 / 1965	1170 / 1995	1380 / 2290
4.4			Reach-out	Laden (Load / Drive)	kg	3835 / 680	4180 / 585	4955 / 715
4.5				Unladen (Load / Drive)	kg	1630 / 1485	1720 / 1445	1915 / 1755
Chassis	5.1	Tyres : Number	Load / Drive / Caster		2 / 1 / -	2 / 1 / -	2 / 1 / -	
	5.2	Tyres	Load	mm	ø254x114 (Urethane)	ø254x114 (Urethane)	ø267x135 (Urethane)	
	5.3		Drive	mm	ø330x145 (Urethane)	ø330x145 (Urethane)	ø380x165 (Urethane)	
	5.4		Caster	mm	-	-	-	
	5.5	Wheelbase		y mm	1350	1450	1500	
	5.6	Tread	Load	mm	1156	1156	1199	
	5.7		Drive	mm	-	-	-	
	5.8	Ground clearance	Middle of wheelbase	F mm	70	70	80	
	5.9	Service brake	Mech. / Hydr. / Electr. / Pneum.		Electr.	Electr.	Electr.	
	5.10	Parking brake	Foot / Hand / Deadman		Deadman	Deadman	Deadman	
Motors	6.1	Battery	Type		DIN C ^{*2)}	DIN C ^{*2)}	DIN C ^{*2)}	
	6.2		Volts / Ampere hrs (5HR)	V/Ah	48 / 360-420	48 / 360-420	48 / 480-560	
	6.3		Mass (with case)	kg	750	750	940	
	6.4	Drive motor	60min. rating	kw	6.0	6.0	7.0	
	6.5		control		Inverter	Inverter	Inverter	
	6.6	Hydraulic motor	5min. rating	kw	12.0	12.0	12.0	
	6.7		control		Inverter	Inverter	Inverter	
	6.8	Power steering motor	60min. rating	kw	0.55	0.55	0.55	
	6.9		control		Chopper	Chopper	Chopper	
	6.10	Charger	Type (Built-in / Stationary)		Stationary	Stationary	Stationary	
7.1	Operating pressure	for Attachments	MPa	15.7	17.2	17.2		

*1) No clearance included. *2) BS type battery is also available.

Rated Capacities and Mast Specifications with Integral Sideshifter

Mast type	Lift height (mm)	Mast specification (mm)							Capacity (Kg) at LC=600					
		Free lift (mm) H ₂ +s			Mast lowered height (mm) H ₁				FBRF14		FBRF16		FBRF20	
		FBRF14	FBRF16	FBRF20	FBRF14	FBRF16	FBRF20	Std. battery	Large battery	Std. battery	Large battery	Std. battery	Large battery	
Three-stage full free mast (Triplex)	430M	4300	1065	1065	1075	1965	1965	1975	1400	1400	1600	1600	2000	2000
	450M	4500	1165	1165	1175	2065	2065	2075	1400	1400	1600	1600	2000	2000
	470M	4700	1215	1215	1225	2115	2115	2125	1400	1400	1600	1600	2000	2000
	500M	5000	1315	1315	1325	2215	2215	2225	1400	1400	1600	1600	2000	2000
	530M	5300	1415	1415	1425	2315	2315	2325	1400	1400	1600	1600	2000	2000
	550M	5500	1515	1515	1525	2415	2415	2425	1400	1400	1600	1600	2000	2000
	570M	5700	1565	1565	1575	2465	2465	2475	1400	1400	1600	1600	2000	2000
	600M	6000	1765	1765	1775	2665	2665	2675	1400	1400	1600	1600	2000	2000
	630M	6300	1815	1815	1825	2715	2715	2725	1350	1400	1550	1600	1900	2000
	650M	6500	1915	1915	1925	2815	2815	2825	1300	1400	1500	1600	1800	2000
	670M	6700	2015	2015	2025	2915	2915	2925	1250	1400	1450	1600	1750	2000
	700M	7000	2165	2165	2175	3065	3065	3075	1200	1400	1400	1600	1700	2000
	730M	7300	2265	2265	2275	3165	3165	3175	1100	1300	1250	1450	1650	1800
	750M	7500	2335	2335	2345	3235	3235	3245	1050	1200	1100	1350	1600	1650
	800M	8000	2495	2495	2505	3395	3395	3405	850	1050	1000	1250	1400	1450
	850M	8500	N/A	2665	2675	N/A	3565	3575	-	-	850	1000	1200	1250
900M	9000	N/A	2835	2845	N/A	3735	3745	-	-	700	850	1000	1050	
950M	9500	N/A	N/A	3005	N/A	N/A	3905	-	-	-	-	800	900	
1000M	10000	N/A	N/A	3175	N/A	N/A	4075	-	-	-	-	600	750	

Note) Mast extended height : Mast lifting height plus 900mm

Battery Specifications

Capacity		Model			Battery Carriage Compartment Wc x Lc mm	O.D. of Case W x L x H mm	Weight Kg	
DIN-C 48V	BS 48V	FBRF14	FBRF16	FBRF20			Min.	Max.
360-420*	360	○	○		288 x 1233	283 x 1223 x 784	710	800
480-560	500*	●	●	○	360 x 1233	355 x 1223 x 784	890	1000
600-700	600*	●	●	●	432 x 1233	427 x 1223 x 784	1060	1210

Note) ○ : Standard, ● : Option

* Available at ex-factory (360Ah for FBRF14/16)

FBRF14

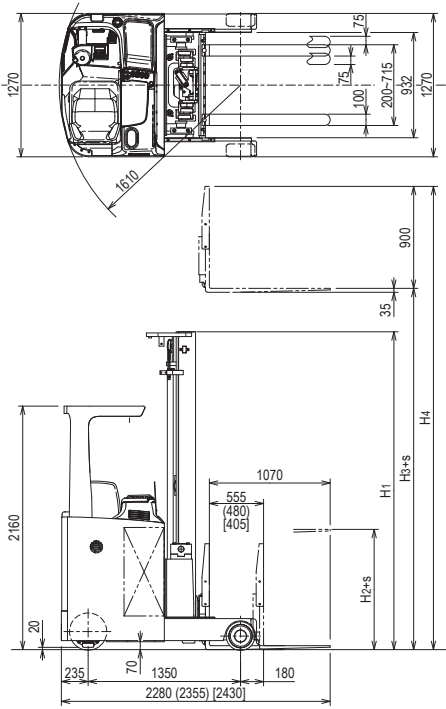

CAPACITY CHART

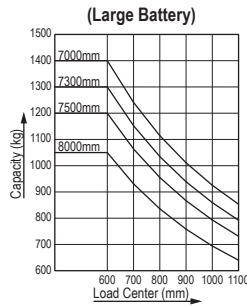
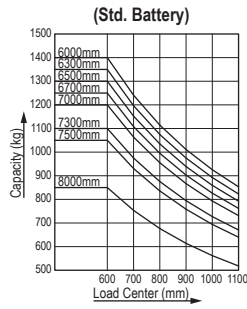

() : with large battery compartment
480-560Ah (DIN), 500Ah (BS)
[] : with large battery compartment
600-700Ah (DIN), 600Ah (BS)

FBRF16

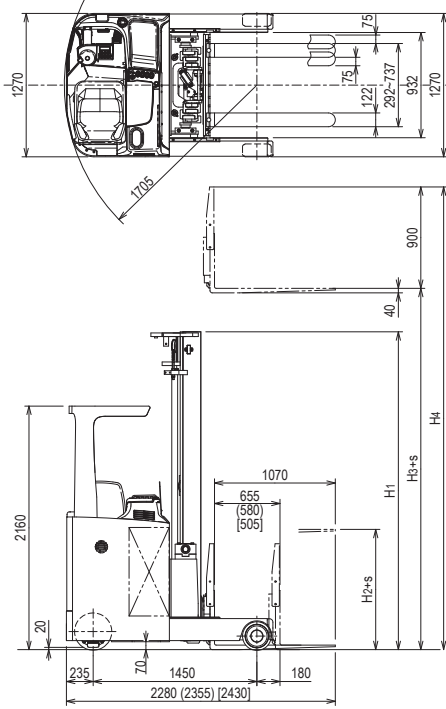

CAPACITY CHART

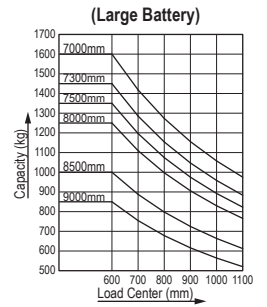
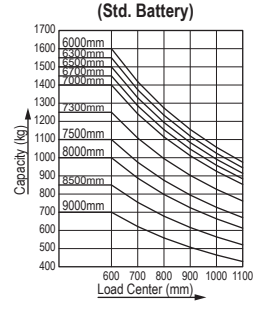

() : with large battery compartment
480-560Ah (DIN), 500Ah (BS)
[] : with large battery compartment
600-700Ah (DIN), 600Ah (BS)

FBRF20

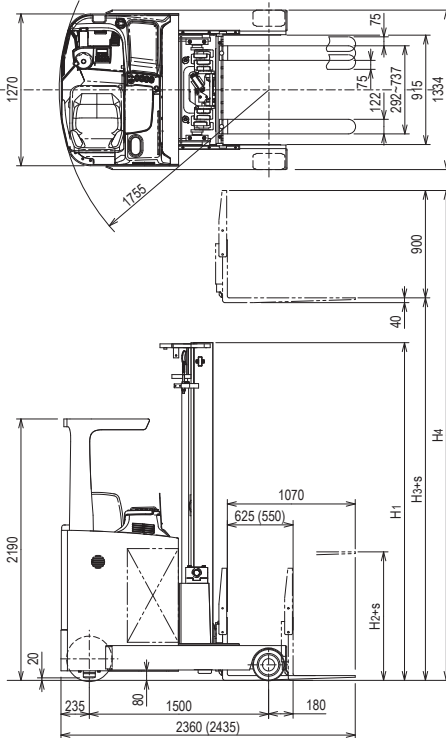

CAPACITY CHART

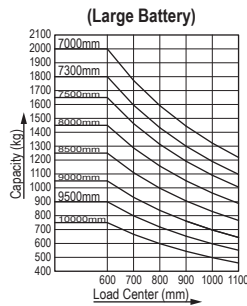
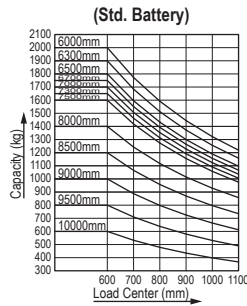

() : with large battery compartment
600-700Ah (DIN), 600Ah (BS)

All specifications have been determined according to Nichiyu's terms and conditions.

Specifications are subject to change without notice in the interests of product improvement.

NICHIYU

Nippon Yusoki Co., Ltd.

1-1, 2-Chome, Higashikotari, Nagaokakyo-shi, Kyoto 617-8585 JAPAN

Tel: +81-(0)75-956-8622 Fax: +81-(0)75-955-0480 URL: <http://www.nichiyu.co.jp/en>

CAT No.OSD096/K75-2 Printed in Japan 5000/1011(C)