



www.doosan-iv.com

7 Series Forklifts

Heavy Forklift 18 to 25 ton Series

EPA Tier IV / Euro Stage IV



Building your tomorrow today

About Doosan

Values that drive our future growth

Trust in people is the foundation upon which Doosan has built its century of success

Over the past 100 years Doosan has always put people first, based on the management philosophy outlined by our first Chairman Too Pyung Park, that "business is not meant to make profits, but to help people grow."

This philosophy continues to spur Doosan's corporate development, with global competitiveness originating from our most valuable resource - our people.

Doosan, Korea's oldest but fastest growing company

Established in 1896, Doosan is Korea's oldest company, but has grown at its most rapid pace for the past 10 years.

Doosan's global Infrastructure Support Business (ISB)

In the past 70% of our business was concentrated on consumer goods, but following reorganisation of our business portfolio in 1998 we have successfully transformed our business DNA to shift the primary focus of our business to infrastructure support.

This means that Doosan now creates more than 90% of its sales through its Infrastructure Support Business

Doosan's growth as a global company

Doosan has become the global ISB leader based on its world class products and services. It is a truly global company, with 50% of its employees based outside of Korea, and overseas trade making up over 60% of the total sales.

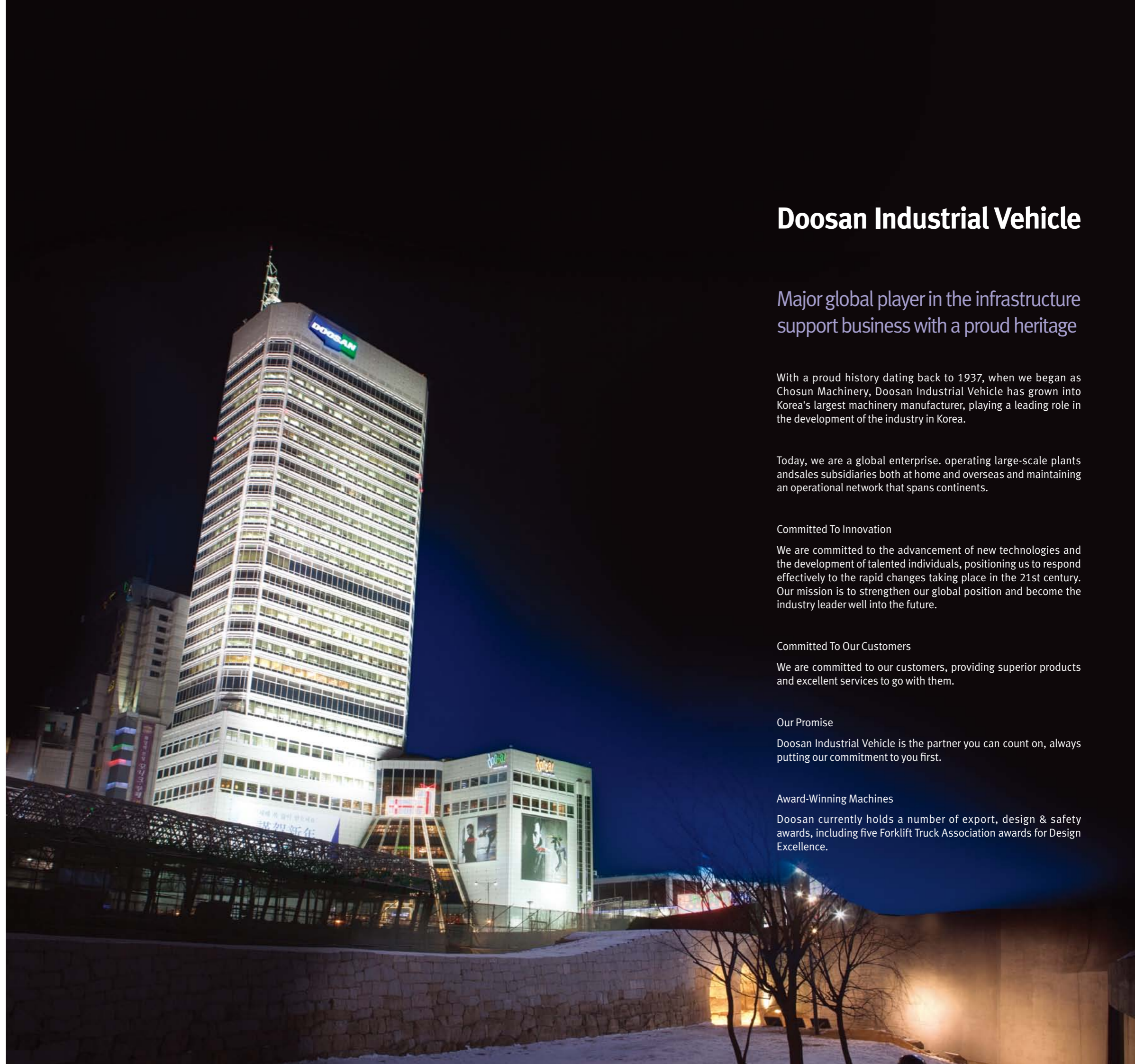

Doosan Industrial Vehicle

Major global player in the infrastructure support business with a proud heritage

With a proud history dating back to 1937, when we began as Chosun Machinery, Doosan Industrial Vehicle has grown into Korea's largest machinery manufacturer, playing a leading role in the development of the industry in Korea.

Today, we are a global enterprise, operating large-scale plants and sales subsidiaries both at home and overseas and maintaining an operational network that spans continents.

Committed To Innovation

We are committed to the advancement of new technologies and the development of talented individuals, positioning us to respond effectively to the rapid changes taking place in the 21st century. Our mission is to strengthen our global position and become the industry leader well into the future.

Committed To Our Customers

We are committed to our customers, providing superior products and excellent services to go with them.

Our Promise

Doosan Industrial Vehicle is the partner you can count on, always putting our commitment to you first.

Award-Winning Machines

Doosan currently holds a number of export, design & safety awards, including five Forklift Truck Association awards for Design Excellence.

7 Series Highlights..

- Meets and exceeds the EPA Tier IV and Euro Stage IV emission regulations by Diesel Oxidation Catalyst(DOC) and Selective Catalytic Reduction(SCR).
- Superb Performance and high power output thanks to the new generation of Doosan's own Diesel Engines.
- Rugged Reliability has been a major part of Doosan's ethos for all of its products.
- A strong and rigid chassis frame along with more metal than plastic design and proven powertrain ensure that Doosan is the best choice for all applications.
- New Zeus Cabin provides wide front view and excellent comfort to operator.
- Reduced Maintenance - Extended service interval means increased uptime and Reduced servicing cost.



Well proven and reliable Doosan DL08P engines and components

Doosan 7.6 litre engine is one of the most powerful and clean engine. DL08P engine provides high-end torque at low engine rpm, reduced fuel consumption and meets EPA Tier IV / Euro Stage IV emission regulations without Diesel Particulate Filter(DPF). Combined with our signature semi-permanent heat treated oil cooled disc brakes, we are able to improve productivity and reduce the cost of maintenance.

Reliable Automatic Transmission

The transmission is particularly smooth and the gear ratio are optimised for heavy lifting. There are no shocks, resulting in an appreciable level of comfort for the operator. The Traction force is optimum under all working conditions, thanks to CANbus information exchange technology. The combination of these characteristics enables the truck to maintain high speed under all conditions.

Load Detection System

By detecting the presence of the load, we are able to channel additional power to the drivetrain to ensure a smooth and efficient operation. The Bosch-Rexroth piston pump with Closed Center Load Sensing(CCLS) technology is applied not only for energy saving, but also providing great comfort to operator while operating and increasing the durability of the engine and hydraulic systems.

Comfortable & Convenient Operator Compartment

Designed to provide greater rigidity and comfort, the Zeus Cabin offers an outstanding visibility, clear dashboard and high quality interior, along with excellent heating and air conditioning.

Safety

OSS (Operator Sensing System)

- Truck will not move without an operator in the seat.
- Lift and Lower function disabled if the operator is not in the seat.
- Tilt function will be locked if no operator is in the seat.
- Alarm will sound if operator leaves the seat without applying parking brake.
- Seat belt warning light on dashboard to remind operator to fasten seat belt.

Meet Emission Regulation (Tier IV & Stage IV) with SCR + DOC System

Extended SCR cleaning interval means increased uptime and reduced servicing cost. No Ash Cleaning or any changing needed.



Greater durability and easier maintenance.

Powerful Doosan's DL08P electronic controlled engine which delivers excellent fuel efficiency is combined with proven automatic transmission and driveaxle. This combination provides great productivity and durability to Doosan heavy forklifts.

Doosan's innovative technology using Diesel Oxidation Catalyst(DOC) and Selective Catalytic Reduction(SCR) ensures the most modern but reliable system is fitted to meet all the latest emission regulation.

Doosan guarantees the highest quality of engines and its components, because we use our own engines, which also means we guarantee the best supply of spare parts at the most competitive prices.

Robust chassis design and heavy duty build quality ensure Doosan's 7-series is tough enough for any application.

Maintenance-free Oil-cooled Disc Brake system ensures maximum up-time, less damage, no maintenance and zero costs for you.



Reliable powertrain

Well-proven driveaxle, transmission system, brakes and other powertrain components are installed. The electronically controlled transmission delivers comfortable and powerful driving at all speeds as well as operating the lifting equipment with high precision.



Durable Steeraxle

The use of an I-beam structured steeraxle adds great strength, whilst bearings in the steeraxle increase rigidity, durability and stability.



Anti Slip Step Plate

Increase safety when operator enters the forklift, especially in the snowy weather.



Easy to access

Thanks to automatic tiltable Operator cell and wide rear hood opening. Operator can access to the key drivetrain components easily and safely.



Easy access Steeraxle grease inlet

The steeraxle grease-inlet hole is located in a central position, ensuring accessibility and ease of grease injection.



Hydraulic Motor Driven Remote type Cooling Fan

A large capacity cooling fan driven by a remote hydraulic motor effectively manages operating temperatures, to minimize engine wear and maximal engine efficiency.

Fan speed changes according to acceleration, for maximum cooling capacity and minimum energy loss.

Reverse fan function included (during 100 second for Radiator cleaning)



All-in-one electronic inch & brake pedal

The all-in-one pedal enables operator to manoeuvre precisely while maintaining high engine revs for the hydraulic functions. The red button control means operator can seamlessly regulate the speed with the brake pedal while lifting at full power.



LED Lights

LED lights give greater visibility in darker conditions and last much longer than conventional light bulbs.



High Powered, Fuel efficient performance.

Powerful and delivering excellent fuel efficiency, Doosan's DL08P electronic controlled engine, combined with already proven transmission and oil-cooled disc brakes(ODB) provide excellent levels of productivity, durability and value for money.

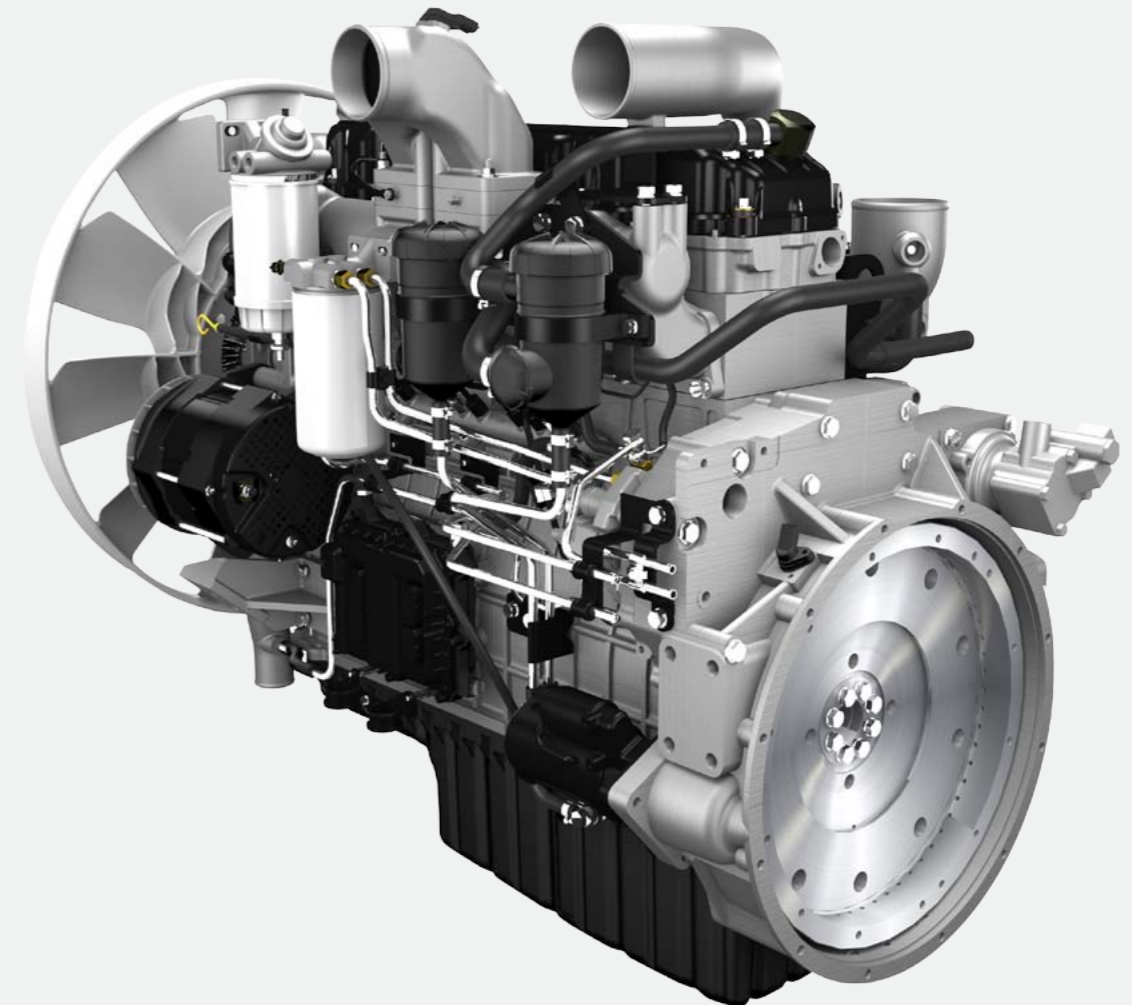

Doosan 7.6 litre Diesel Engine

Doosan 7.6 litre Diesel Engine offers high power output and Max. torque, moreover maintains the highest level of performance for the most challenging conditions in the most challenging applications.

- Advanced fuel injection system : The advanced fuel injection system enables accurate fuel injection control thanks to its high pressure of the common rail. This unique technology of Doosan 7.6 litre Diesel Engine improves performance and fuel efficiency, while reducing emissions, noise and vibration.
- Variable Geometry Turbocharger : Designed to allow the effective aspect ratio of the turbo to be altered as conditions change. By altering the geometry of the turbine housing as the engine accelerates, the turbo's aspect ratio can be maintained at its optimum. Because of this, VGT have a minimal amount of lag, have a low boost threshold, and are very efficient at higher engine speeds.

Category	Unit	Doosan	
Model	-	DV180S-7	DV250S-7
Engine	-	Doosan DL08P	
Rated Output	kW/rpm	183.7 / 2,100	213.3 / 2,100
Max. Torque	Nm/rpm	1,157 / 1,300	1,236 / 1,300
No. of Cylinders	-	6	
No. of Cycle	-	4	
Displacement	cc	7,640	



Aftertreatment System

- Diesel Oxidation Catalyst(DOC) : The primary functions are oxidation of CO, unburned hydrocarbons, and NO, while active hydrocarbon oxidation can also be used to generate exotherms required for downstream components.
 - Selective Catalyst Reduction(SCR) System : Technology that uses a Diesel Exhaust Fluid(DEF) and a catalytic converter to significantly reduce NOx emissions.
- * Need SCR cleaning process every 150 hrs / SCR Cleaning is available anytime with its switch operation.

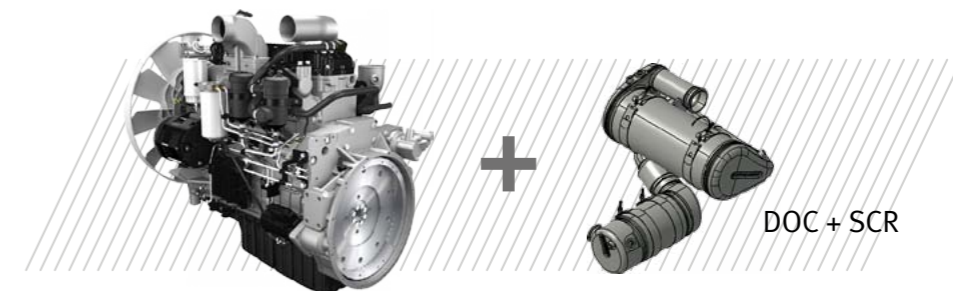

[NOx+HC] PM
NOx/HC/PM
P/I : Phase In
P/O : Phase Out

What is the EEA & EPA?

- EEA : European Environment Agency
- EPA : Environment Protection Agency

The EEA and EPA are the department of the European Union and the United States that is responsible for writing and enforcing regulations based on laws to protect human health and the environment. Directive 1999/94/EC requires the reduction of emissions, especially Particulate Matter(PM) and Nitrogen Oxides(NOx), in non-road diesel engine vehicles. The different stages of the directive are based on engine power and are designed to phase in the new levels of requirements

		2008	2009	2010	2011	2012	2013	2014	2015	
North America	19≤kW<37	Tier IV Interim [7.5]/0.3					Tier IV [4.7]/0.03			
	37≤kW<56	Tier III [4.7]/0.4				Tier IV Interim [4.7]/0.3		Tier IV [4.7]/0.03		
	56≤kW<75						Tier IV Interim 3.4/0.19/0.02			Tier IV 0.40/0.19/0.02
	75≤kW<130	Tier III [4.7]/0.3								
	130≤kW<560	Tier III [4.7]/0.2				Tier IV Interim 2.0/0.19/0.02				
Europe	19≤kW<37	Stage IIIA [7.5]/0.6								
	37≤kW<56						Stage IIIB [4.7]/0.025			
	56≤kW<75	Stage IIIA [4.7]/0.4					Stage IIIB 3.3/0.19/0.025			Stage IV 0.4/0.19/0.25
	75≤kW<130	Stage IIIA [4.0]/0.3								
	130≤kW<560	Stage IIIA [4.0]/0.2				Stage IIIB [2.0]/0.025				

Eco-Friendly and more...

Doosan's unique and innovative Ultra-Low Particulate Matter Combustion system using Selective Catalytic Reduction(SCR) and Diesel Oxidation Catalyst (DOC) is the most modern and reliable system to comply to all emission regulations.

No Diesel Particulate Filter(DPF) and fully extended SCR cleaning interval means maximum up-time and minimum maintenance cost.

Doosan implements the regulations and emissions standards to protect the environment for the future of the earth.

Diesel Off-Highway Emissions Evolution

EPA Tier IV & EU Stage IV come in to effect from 2014 for over 130kW engine
For the implementation of regulations PM and NOx should be reduced by 90% compare to EPA Tier III / EU Stage IIIA.

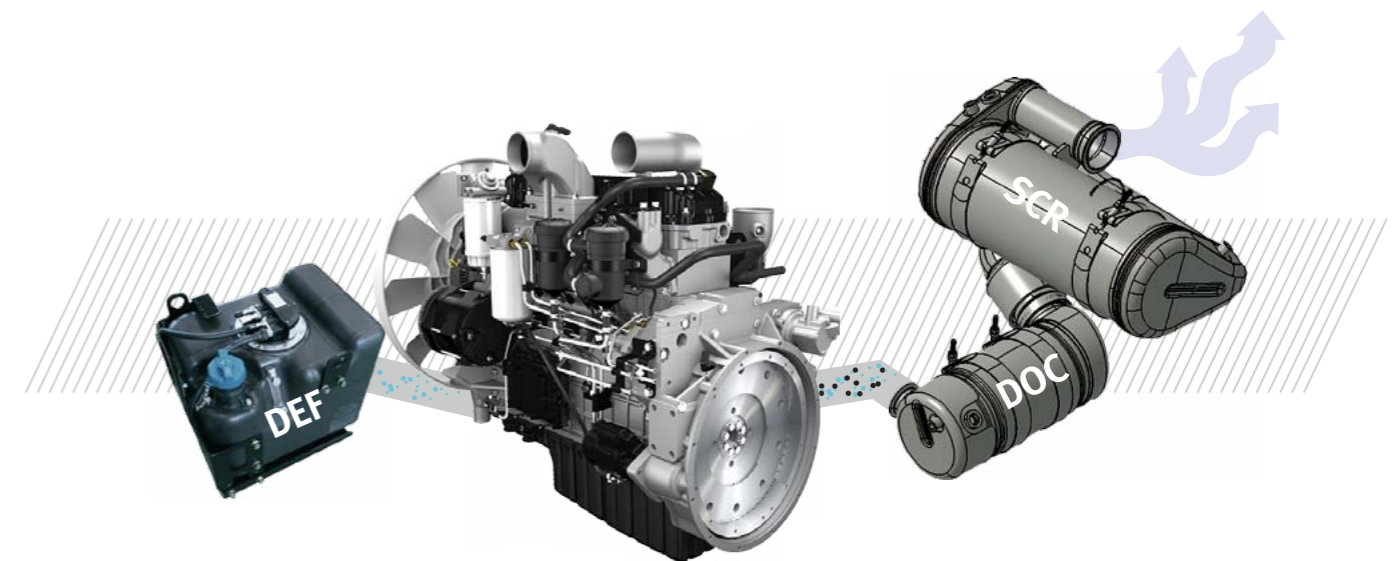

Doosan's green technology to meet Tier IV(Stage IV) emissions regulations

- Exhaust Gas Reduction (EGR)
- Diesel Oxidation Catalysts (DOC) : Oxidizing HC, CO, SOF and Converting NO into NO2
- Selective Catalyst Reduction (SCR) : Reducing Nox
- Diesel Exhaust Fluid(DEF) : Helping reduce Ammonia



Doosan Zeus Cabin, Great Comfort and Productivity

The Zeus Cabin provides to operator not only great comfort, but also higher productivity with ergonomically design features.

Doosan guarantees the highest quality of Cabin and its components.



Ergonomic Design

- All switches are positioned for optimal operator's convenience.
- Extremely comfortable suspension seat.
- Ergonomic parking lever position at the left side of seat. (Left side of seat)

Spacious Leg Room and Operator Comfort

- The neat and wide-open floorboard provides operator with plenty of leg space to make entry and exit a breeze.
- Low Noise Level and Low Vibration Level.
- Telescopic Steering Column : Infinitely adjusts to a wide range for operators of all sizes.

Wide Visibility

- Centered seat for better visibility.
- Wide visibility without distortion.



5" Full Color LCD Display

- DEF warning, DEF level gauge, SCR cleaning request, SCR cleaning inhibit, Engine RPM and Engine check lamp keeps operator aware of machine's operating and maintenance conditions.



Convenience Package

- Deck mounted control valve levers simplify hydraulic actuation. Convenience tray keeps paperwork and supplies organized and handy.

Other Features

- Heater
- Air Conditioner
- Panoramic Mirror
- MP3 Player
- Front & Rear View Camera
- Defrost Fan
- Rear Grab Bar with Horn
- Siren & Microphone
- Air Compressor

Proven Quality, Service and A Reliable Partner.

You will receive the best after-sales service from your authorized local or national factory-trained dealer, backed by Doosan's own customer service center.

And Doosan provides 100% parts inventory, to insure downtime is kept to a strict minimum.

When you own a Doosan forklift, our high quality, responsive customer support team comes with it.

The Doosan network starts with your local dealer and ends with a national team of highly qualified and experienced personnel standing ready to support all your material handling needs.

Standard features and Option Availability

	Standard	Option
Safety		
Direction Lever Function	<input checked="" type="radio"/>	
Operation Sensing System	<input checked="" type="radio"/>	
Anti Cinching Type Orange Seat Belt	<input checked="" type="radio"/>	
Autoshift Controller	<input checked="" type="radio"/>	
Emergency Switch	<input checked="" type="radio"/>	
Panoramic Rear View Mirror	<input checked="" type="radio"/>	
Combination Lamps	<input checked="" type="radio"/>	
Tilt Forward 6° Warning Alarm	<input checked="" type="radio"/>	
Back-up buzzer	<input checked="" type="radio"/>	
Side Mirrors with Heat rays	<input checked="" type="radio"/>	
Weight Scale(Load Cell type)		<input type="radio"/>
Siren and Microphone		<input type="radio"/>
2 Front 1 Rear View Camera		<input type="radio"/>
Rear View Camera(w/ Steer tire angle)		<input type="radio"/>
Strobe Light(Amber / Red, LED)		<input type="radio"/>
Ground Speed Control		<input type="radio"/>
Productivity		
Electric Controlled TCI(Turbo Charged Intercooler) Doosan Engines	<input checked="" type="radio"/>	
Pedal Location(Accelerator, Brake and Inching)	<input checked="" type="radio"/>	
All in one electronic Brake and Inching Pedal	<input checked="" type="radio"/>	
Rear Grab Bar(w/ Horn)	<input checked="" type="radio"/>	
2 Front LED Lights on Mast(DV180S-7 only)	<input checked="" type="radio"/>	
4 Front LED Lights on Mast(DV250S-7 only)	<input checked="" type="radio"/>	
2 Rear Lights on Counterweight		<input type="radio"/>
Comfort		
Telescopic Steering column	<input checked="" type="radio"/>	
Integrated Instrument Panel	<input checked="" type="radio"/>	
Seat - Suspension w/ Heat Rays	<input checked="" type="radio"/>	
Easy to Service	<input checked="" type="radio"/>	
- Integrated Electric Components(Relays and Fuses)		
- Automatic Tilttable OPC		
- Wide Hood Open Range		
Full Cabin(ZEUS)	<input checked="" type="radio"/>	
- Wide Front and Rear View		
- Low noise & Low Vibration Level		
- Automatic Tilttable		
- Front, Rear & Top Wiper		
- MP3 Player		
- Sun Visor		
Heater		<input type="radio"/>
Air Conditioner		<input type="radio"/>
Steering Knob		<input type="radio"/>
Sound Suppression(Only for DV180S-7)		<input type="radio"/>
Air Compressor		<input type="radio"/>
Durability		
Use waterproof connectors	<input checked="" type="radio"/>	
Dual Element Air Cleaner	<input checked="" type="radio"/>	
Rigid Driveaxle(w/ ODB)	<input checked="" type="radio"/>	
Full Autoshift Transmission	<input checked="" type="radio"/>	
Environment		
Emission Regulation(Tier IV and Stage IV)	<input checked="" type="radio"/>	
ISO 9001 / ISO 14001	<input checked="" type="radio"/>	
Homologation		
UL		<input type="radio"/>
CE		<input type="radio"/>

* Other options are also available. Please ask your local Doosan representative for more details.

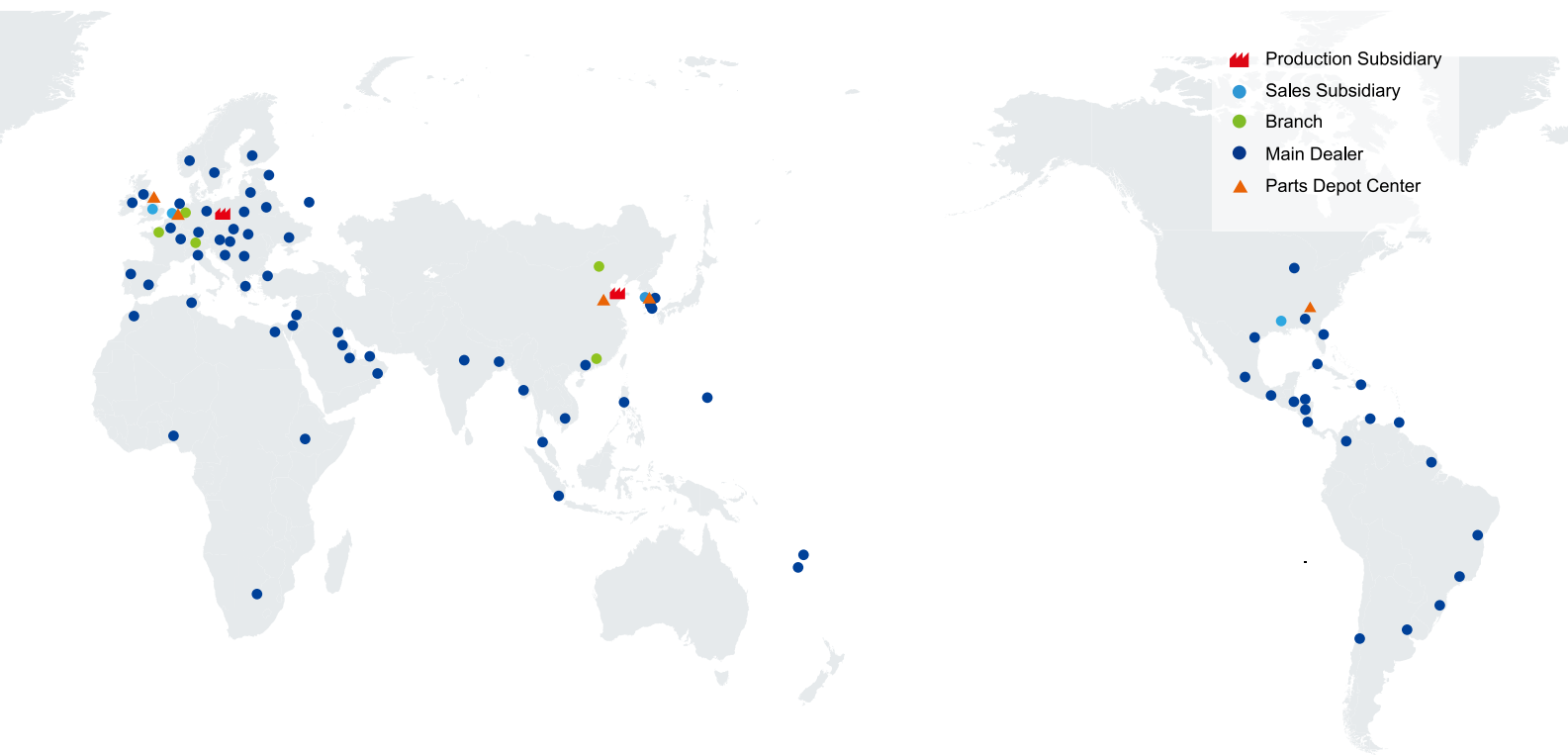

Doosan Corporation Industrial Vehicle
Web site : www.doosan-iv.com

2017 May

AUTHORIZED DEALER